



250 N

Chiavi a forchetta doppie piccole



DATI TECNICI

- Forchette di uguale misura inclinate di 15° e 75°

NORMATIVE

- ISO 691 ISO 3318



250 N

Chiavi a forchetta doppie piccole

DISEGNO



TABELLA DISEGNO

Codice	Misura	L	T	T1	T2	A	B	C	L1	L2	Durezza HRC
U02500103	3.2	70				10	10	5	5	5	45÷49
U02500104	4										
U02500105	4.5	75	2.4	1.7	2.4	13	13	6	6.5	6.5	
U02500106	5										
U02500107	5.5										
U02500108	6	80	2.7	2	2.7	15	15	6	7.5	7.5	
U02500110	7										
U02500111	8	90	3	2.3	3	18.5	18.5	7.5	9.25	9.25	
U02500112	9										
U02500113	10										
U02500114	11	100				22	22	8.5	11.2	11.2	
U02500115	12										
U02500116	13										
U02500117	14	120	3.5	2.7	3.5	27	27	10	13.6	13.6	

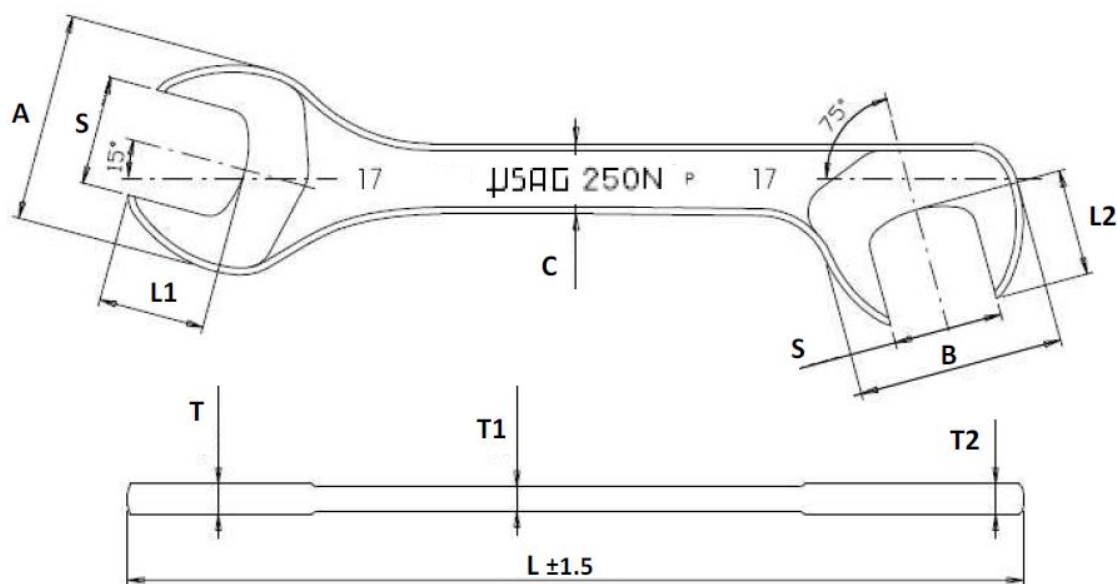

250 N

Chiavi a forchetta doppie piccole

MATERIALI

Acciaio: 6140

Finitura: Cromata satinata

CONFEZIONAMENTO

- Scatola di cartone 5 pz

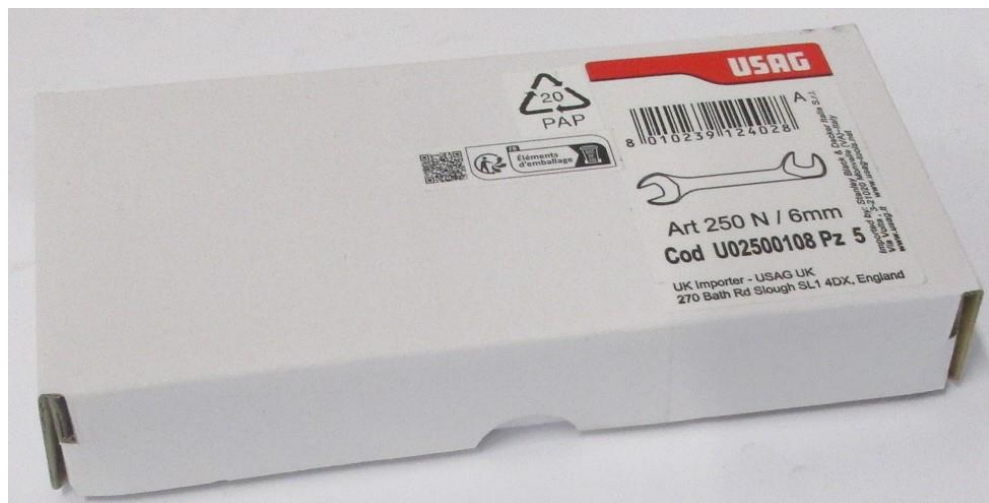

Stanley Black & Decker Italia Srl
Via Volta, 3 - 21020 Monvalle (VA)
Tel. +39 0332 790111 - Fax +39 0332 790330
info.mv@usag.it

USAG.IT
USAG-TOOLS.NET

UK Importer - USAG UK, 270 Bath Rd, Slough SL1 4DX, England